

THE INFORMATION CONTAINED IN THIS DRAWING IS THE SOLE PROPERTY OF SUSPA INCORPORATED. ANY REPRODUCTION IN PART OR AS A WHOLE WITHOUT THE WRITTEN PERMISSION OF SUSPA INCORPORATED IS PROHIBITED.

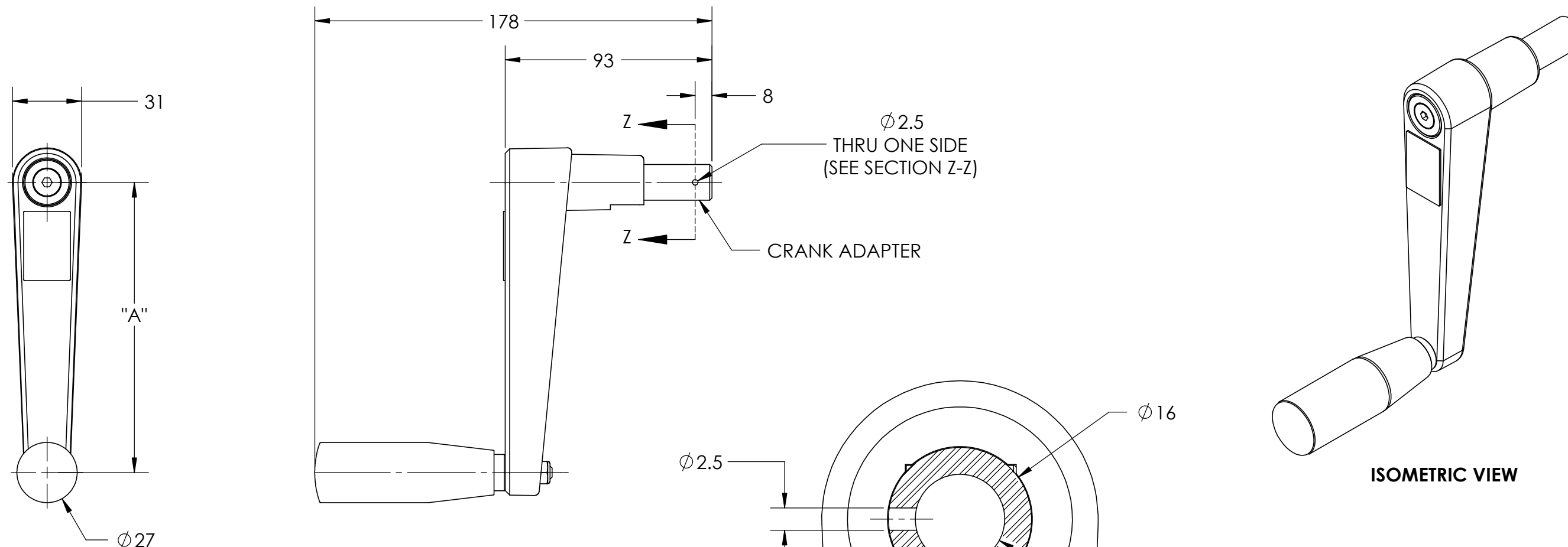

CRANK KIT P/N	CRANK P/N	CRANK DESCRIPTION	"A" DIMENSION
D99-00037A	D44-00022	130MM STANDARD CRANK	130
D99-00038A	D44-00023	100MM STANDARD CRANK	100
D99-00039A	D44-00024	130MM STAINLESS CRANK	130
D99-00040A	D44-00025	100MM STAINLESS CRANK	100

NOTES:

- ALL DIMENSIONS ARE REFERENCE ONLY.
- CRANK KITS ARE ALSO AVAILABLE (SEE TABLE ABOVE). KITS INCLUDE CRANK WITH PRE-DRILLED HOLE, (1) 2.5MM DRILL BIT, (2) ROLL PINS, AND INSTRUCTIONS.

SECTION Z-Z
SCALE 2 : 1

DO NOT MANUFACTURE TO THIS DRAWING UNLESS IT IS MARKED "CONTROLLED"

DO NOT SCALE THIS DRAWING
DIMENSIONS ARE IN MILLIMETERS
TOLERANCES UNLESS OTHERWISE SPECIFIED

ONE PLACE DECIMAL	+/-0.2	ANGULAR	+/-2°
TWO PLACE DECIMAL	+/-0.1		

DRAWN BY	DATE	SCALE	THIRD ANGLE PROJECTION
MJF	07/9/07	1:2	

CUSTOMER DRAWING

REV	ECN	DESCRIPTION	CHANGED BY	APPROVED BY	DATE (MM/DD/YR)
A	B764	UPDATED MODEL WITH NEW CRANK HANDLE		KTB	05/26/17
		RELEASED		MJF	7/10/07
CRANK W/PILOT HOLE					
MATERIAL N/A					
DRAWING NUMBER S44-0018A					
3970 Roger B. Chaffee S.E. Grand Rapids, Michigan 49548-3497 www.suspa-inc.com INCORPORATED					DRAWING SIZE B